

# **HAMLET<sup>®</sup>**

***EXCELLENCE IN VISION***

---

## **MS9000A/B**

**HD, SD & CST WAVEFORM, VECTOR,  
AUDIO AND PICTURE MONITOR  
AND TEST PATTERN GENERATOR**

### **OPERATOR'S HANDBOOK**

**V1.4 onwards**

© 2008 Hamlet Video International Ltd. All rights reserved

This handbook contains proprietary information of Hamlet Video International Limited and may not be copied in whole or in part nor its contents disclosed to any third parties without the express written consent of the company.

**Corporate Head Office**

Hamlet Video International Limited.

Maple House, 11 Corinium Business Centre, Raans Road, Amersham, Bucks HP6 6FB England.

Main Line: +44 (0)1494 729 728, Fax Line: +44 (0)1494 723 237, Free phone (UK): 0500 625 525

E-mail: [service@hamlet.co.uk](mailto:service@hamlet.co.uk) Web site: [www.hamlet.co.uk](http://www.hamlet.co.uk)

**Hamlet USA**

Sencore, Inc. 3200 W Sencore Drive, Sioux Falls SD 57107, U.S.A. Phone: (605) 339-0100 Fax: (605) 339-

7032 Toll Free: 1-800-SENCORE (736-2673) or 1-866-4-HAMLET (426-538)

Email: [service@sencore.com](mailto:service@sencore.com) Web site: [www.hamlet.us.com](http://www.hamlet.us.com)

IN CORRESPONDENCE CONCERNING THIS INSTRUMENT  
PLEASE QUOTE THE SERIAL NUMBER PRINTED ON THE  
LABEL AT THE REAR OF THE UNIT

## VERSIONS

### **A**

Full specification unit.

### **B**

Tile mode is restricted to the waveform and video vector display.  
Cursor measurements are disabled.

## CONTENTS

### GENERAL INFORMATION

List of figures	4
Warranty	5
Safety and EMC	6
Product disposal instructions	6
Overview	7
Case view	8

<b>GETTING STARTED</b>	9
------------------------	---

### OPERATING INSTRUCTIONS

Waveform menu	12
Vector menu	13
Audio menu	14
Cursor menu	16
Logger menu	17
Alarm menu	18
Data menu	19
Display menu	20

<b>Remote control:</b>	21
------------------------	----

<b>Additional functions</b>	22
Power source	22

<b>TECHNICAL SPECIFICATION</b>	23
--------------------------------	----

Troubleshooting	25
SD Serial Digital Basics	26
HD Serial Digital Basics	31
Composite Basics	36
Useful Websites	39
Contact details and customer support	39

<b>TEST PATTERN GENERATOR OPTION</b>	40
--------------------------------------	----

## FIGURES

Fig 1	Case View	8
Fig 2	Status Display	10
Fig 3	Waveform Menu	12
Fig 4	Vector Menu	13
Fig 5	Audio Menu	14
Fig 6	Audio Scales	15
Fig 7	Cursor Menu	16
Fig 8	Logger Menu	17
Fig 9	Alarm Menu	18
Fig 10	Data Menu	19
Fig 11	Display Menu	20
Fig 12	SD Serial Digital Basics	29
Fig 13	625 Field Blanking	30
Fig 14	525 Field Blanking	30
Fig 15	HD sample structure	32
Fig 16	HD embedded audio	34
Fig 17	PAL Basics	37
Fig 18	NTSC Basics	38

## GENERAL INFORMATION

### WARRANTY

This product is manufactured by Hamlet Video International Ltd and is warranted to be free from defects in components and factory workmanship under normal use and service for a period of one year from the date of purchase.

### FREE EXTENDED WARRANTY

The warranty period can be extended to two years by registering the instrument on the Hamlet web site

<http://www.hamlet.co.uk/serv.html>

### TERMS AND CONDITIONS

During the warranty period, Hamlet Video International Ltd will undertake to repair or at its option, replace this product at no charge to its owner when failing to perform as specified, provided the unit is returned shipping prepaid, to the factory or authorised service facility.

No other warranty is expressed or implied. Warranty shall not be applicable and be void when this product is subjected to:

1. Repair work or alteration by persons other than those authorised by Hamlet Video International Ltd in such a manner as to injure the performance, stability, reliability or safety of this product.
2. Misuse, negligence, accident, act of God, war or civil insurrection.
3. Connection, installation, adjustment or use otherwise than in accordance with the instructions in this manual.

Hamlet Video International Ltd reserves the right to alter specifications without notice. This warranty does not affect the statutory rights of the UK customer.

## GENERAL INFORMATION

### SAFETY COMPLIANCE

This product is manufactured and tested to comply with **BS EN 61010-1 : 1993**  
Safety requirements for electrical equipment for measurement, control and laboratory use.



### EMC COMPLIANCE

We, Hamlet Video International Limited, Maple House, 11 Corinium Business Centre, Raans Road, Amersham, Bucks, HP6 6FB, England, declare under our sole responsibility that the product **HAMLET MS9000** to which this declaration relates is in conformity with the following standards:

**EN50081-1** Generic emissions standard for light industrial applications.

**EN50082-1** Generic immunity standard for light industrial applications.

Following the provisions of EU EMC directives 89/336/EEC and 92/31/EEC.

**NOTE.** During the EMC certification of this product, shielded cables were used.  
We recommend that they be used in operation.

### PRODUCT DISPOSAL INSTRUCTIONS

**B2B COMPLIANCE REG NO.**  
**WEE/GJ0146QT**

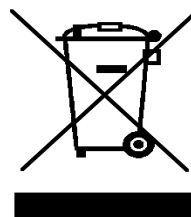

The symbol shown above and on the Hamlet MS9000 means the product is classed as Electrical or Electronic Equipment and should not be disposed with other commercial waste at the end of its working life. The Producer Registration Number above, WEE/GJ0146QT proves that Hamlet are formally registered with a legally approved Compliance Scheme. The Scheme we are registered with is called "B2B Compliance". B2B Compliance takes on the legal responsibilities of the reporting on, and the collection and treatment of, all WEEE that Hamlet Video International Limited is obliged for - and ensures that the appropriate recycling targets are met on this WEEE

The Waste of Electrical and Electronic Equipment (WEEE) Directive (2002/96/EC) has been put in place to recycle products using best available recovery and recycling techniques to minimise the impact on the environment, treat any hazardous substances and avoid the increasing landfill.

#### **Product disposal instructions for business users.**

Business users in the EU should contact their Hamlet MS9000 supplier to arrange for its return to Hamlet head office in the UK, who will safely dispose of it and ensure that this Hamlet MS9000 is not mixed with other commercial waste for disposal.

## OVERVIEW

The Hamlet MS9000 is a 3U high, half rack width HD, SD and Composite capable waveform and picture monitor, with vectors and embedded/AES audio monitoring and optional HD-SD test pattern generator.

### **Option 1**

The HD-SD input option accepts all major high definition and standard definition serial digital video standards.

### **Option 2**

The SD-CST input option accepts Serial Digital video in 625 and 525 line standards and Composite video in PAL and NTSC standards.

### **Option 3**

The HD-SD test pattern generator module offers all the features of the HD-SD input module, with the addition of test pattern outputs in all major high definition and standard definition serial digital video standards. Two option modules of any type can be fitted.

The MS9000 displays the waveforms on its internal high quality 6.5" X VGA 1024 x 768 high contrast TFT liquid crystal display. The output option allows the use of an external analogue or digital monitor, via a DVI-I socket.

All the standard displays are produced, including H and V Mag, Line Select, Component Parade, Filter Parade and Bowtie. Proprietary patented digital signal processing produces displays with the look of a CRT but without the problems of scan burn, EHT difficulties etc. The very low power consumption also allows it to be used in the field from an external 12V supply or an optional rechargeable battery pack.

There are also displays of four channels of audio and a vector audio phase display. The unit contains a high specification audio de-embedder, which displays on the audio bar graphs and outputs analog stereo audio to a front panel mounted headphone jack.

The serial digital signal itself is analysed to give on-screen readouts of the various digital parameter errors and signal strength in the top of screen status bar.

Measurement cursors are provided to allow amplitude and timing differences to be measured between two points on the waveform display and to provide vector phase and amplitude on the vector display.

The full screen picture mode allows the MS9000 to act as a high quality picture monitor.

Remote control software allows all functions to be controlled from a personal computer and for waveforms to be downloaded to a computer for display and storage.

# CASE VIEW

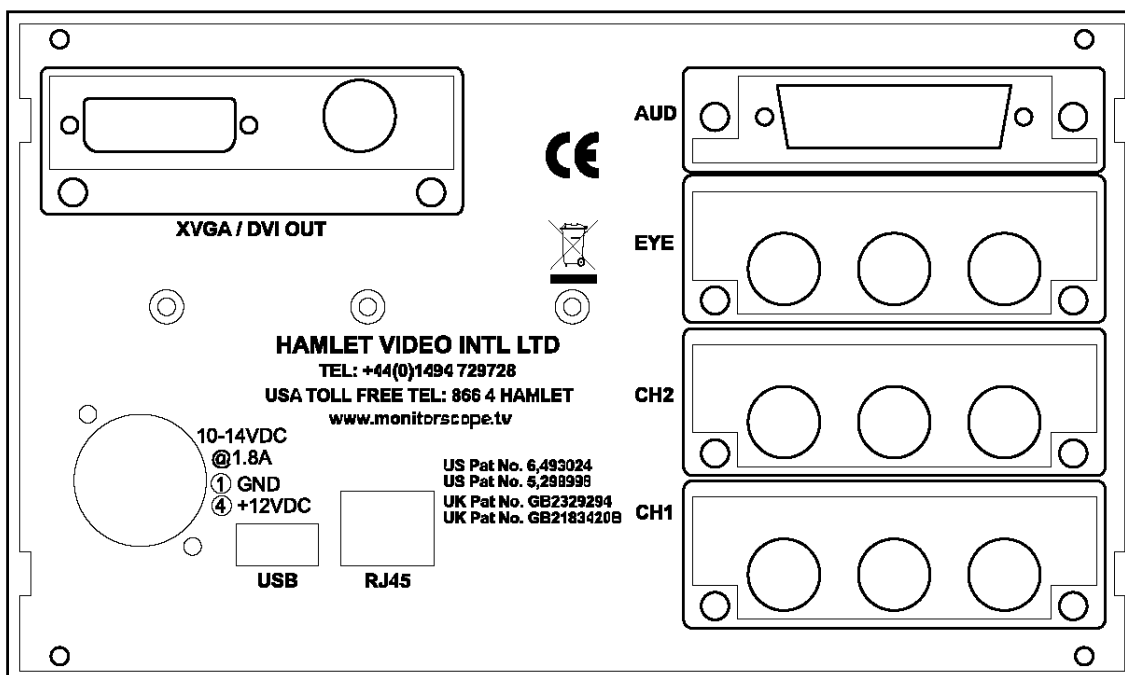
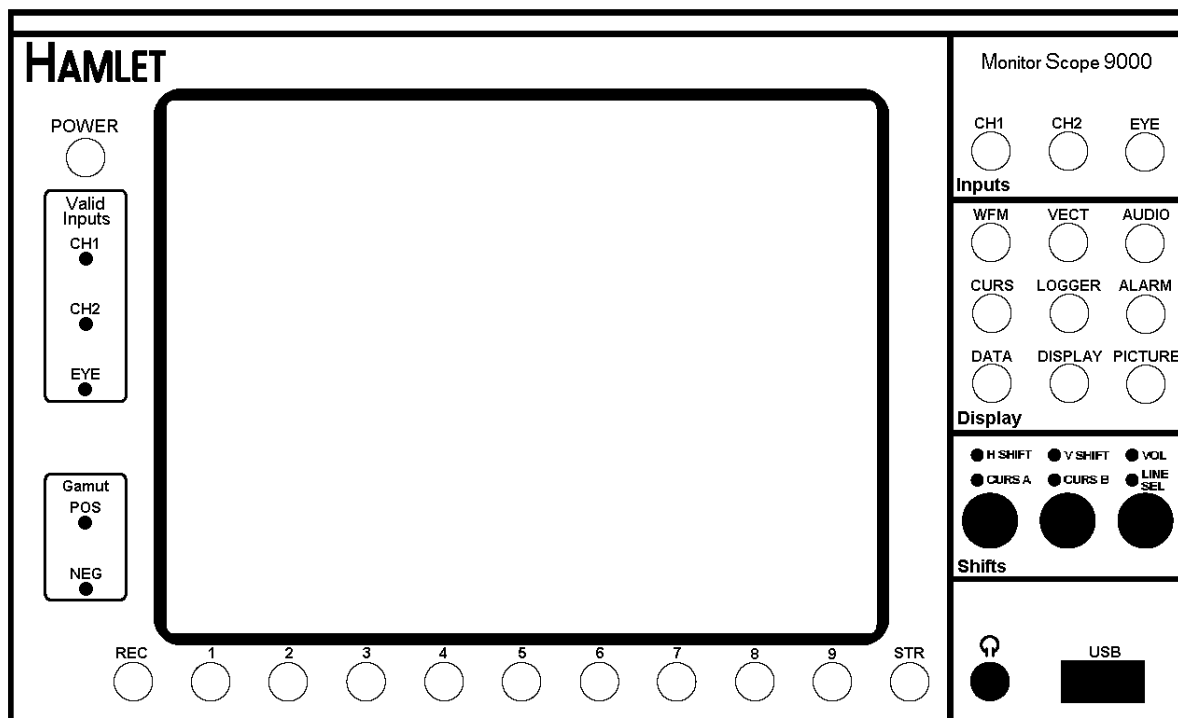

Fig 1

## GETTING STARTED

### UNPACKING

The Hamlet MS9000 is shipped from the factory in a specially constructed packing case. Exercise caution when unpacking the unit to prevent damage to the case finish. Examine the unit carefully for damage, which may have occurred during shipment, if severely handled.

### POWER REQUIREMENTS

The Hamlet MS9000 should be powered from the supplied adaptor, or a regulated supply of 12VDC of at least 2 Amps rating, to the 4 pin XLR power socket.

### SIGNAL AND CONTROL CONNECTIONS

#### Option 1 card input (either slot)

The HD/SD serial input connection is made to the centre gold plated BNC socket, which is internally terminated at 75 ohms. The left BNC provides an equalised output of the input feed and the right BNC allows an external timing reference or AES audio signal to be input.

#### Option 2 card input (either slot)

The SDI / CST input connection is made to the centre BNC socket, which is internally terminated at 75 ohms. The left BNC provides an equalised output of the input feed in SDI mode and the right BNC allows an external timing reference or AES audio signal to be input.

#### Option 3 card input/output (either slot)

The HD/SD input connection is made to the centre BNC socket, which is internally terminated with 75 ohms. The left BNC outputs the selected test pattern and the right BNC allows an external timing reference or AES audio signal to be input.

#### Output option

An external digital or analogue XVGA monitor can be connected to the DVI-I sockets. The standard is XVGA 1024x768 @ 60Hz.

### PREVENTATIVE MAINTENANCE

The Hamlet MS9000 should be visually inspected and cleaned every one year of operation.

**CAUTION.** The display screen is made from polycarbonate, which may soften if cleaned with some organic solvents. Do not allow water to get inside the equipment case.

The internal clock battery will need replacing every 5 years approximately with a CR2032 type.

## GETTING STARTED

1. Connect the supplied 12V power adaptor output to the rear XLR socket.
2. Apply AC mains (100 - 250VAC) to the power adaptor.
3. Connect an appropriate video feed to the CH1 option centre BNC.
4. Press the front panel PWR key. The software versions will be displayed for the first two seconds.
5. The MS9000 remembers all the setting when it was previously used. If the icon menu is not visible, it may be in picture mode. Press the WFM key to cancel this.
6. Press the DATA key, then press the menu key pointing to the FAC icon for two seconds to restore factory defaults. This will show a waveform display in 1H timebase range.

## TYPICAL STATUS DISPLAY

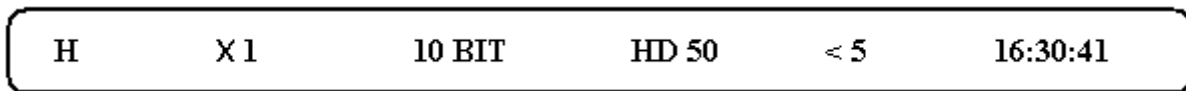

Fig 2

**H** is the time base range.

**X1** is the vertical gain.

**10BIT** shows the number of active bits per pixel.

**HD50** is the television standard.

**<5** is an indication of SDI cable attenuation in dB.

The internal real time clock displays on the right of the status screen and has a battery backup for at least 5 years. It will also display any VITC timecode on the input signal.

All MS9000 functions are controlled from a simple menu structure.

## OPERATING INSTRUCTIONS

### FRONT PANEL

Control keys allow direct access to all the major functions, with sub functions controlled by a simple menu system.

**VALID** Lights to shows which input has a valid signal present.

### INPUTS

**CH1** Selects the Channel 1 input option when fitted.

**CH2** Selects the Channel 2 input option when fitted.

**EYE** Selects the Eye Pattern input option (future option).

**WFM** Selects waveform monitor mode.

**VECT** Selects vector monitor mode.

**AUDIO** Selects audio monitor mode.

**CURSOR** Selects measurement cursor mode.

**LOGGER** Selects error logger mode and real time clock setting.

**ALARM** Selects which errors are logged or cause an audible alarm.

**DATA** Selects data and sundry functions.

**DISPLAY** Selects the display options.

**PICTURE** Selects picture monitor mode.

### GAMUT ERRORS

**POS** Lights if the low pass filtered Y signal is high by 3% or more.

**NEG** Lights if the low pass filtered Y signal is low by 1% or more.

## OPERATING INSTRUCTIONS

### WAVEFORM MENU

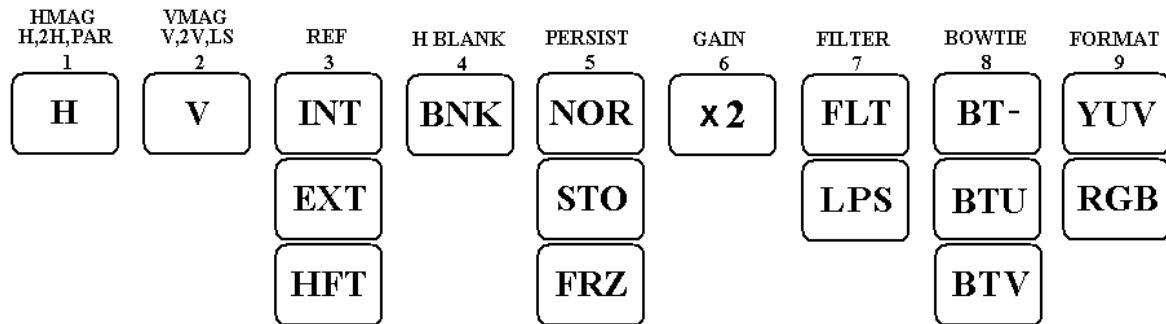

- 1 **H**
 Selects horizontal timebase ranges of H, 2H, Parade and Hmag.  
 In HD Hmag range, the graticule major divisions are 200nSec apart.
- 2 **V**
 Selects horizontal timebase ranges of V, 2V, Vmag and Line Select.  
 The front panel LINE SEL control selects the line number.
- 3 **INT**
INT Selects internal sync reference from the input video.  
EXT Selects the EXT-REF bnc as the sync reference.  
HFT Hands Free Timing™ automatically switches the display between internal and external syncs, so easily showing timing errors.
- 4 **BNK**
 Blanks out the horizontal blanking area (TRS, audio, aux data etc).
- 5 **NOR**
NOR Selects the display persistence to the normal frame rate.  
STO Selects the display persistence to infinite.  
FRZ Freezes the display.
- 6 **x 2**
 Toggles the video gain between x1 and x2 values.
- 7 **FLT**
FLT Selects Flat video filter.  
LPS Selects Low Pass video filter.
- 8 **BT-**
BT- Selects Bowtie OFF.  
BTU Selects Bowtie Y-U.  
BTV Selects Bowtie Y-V.
- 9 **YUV**
YUV Selects YUV waveform display in 3H timebase range.  
RGB Selects RGB waveform display in 3H timebase range.

The waveform display can be moved horizontally and vertically using the front panel H SHIFT and V SHIFT controls.

Fig 3

## OPERATING INSTRUCTIONS

### VECTOR MENU

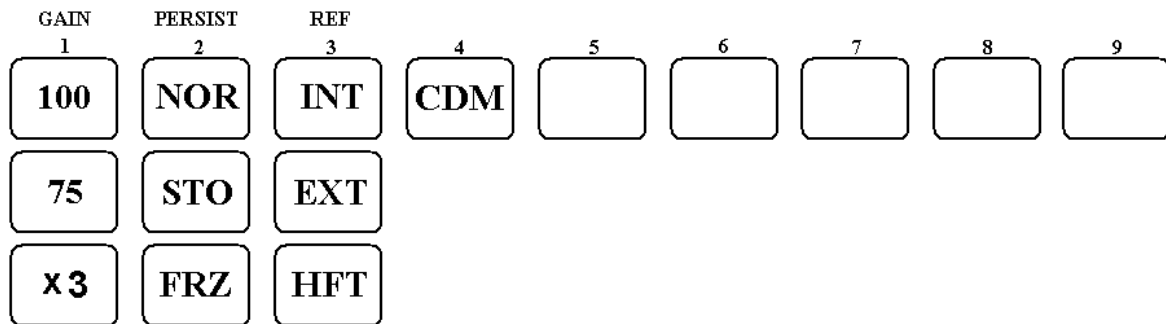

- 1 **100**
**100** Sets the vectorscope gain for 100% vectors.  
**75** Sets the vectorscope gain for 75% vectors.  
**x3** Sets the vectorscope gain to 3 times the 100 setting.
- 2 **NOR**
**NOR** Selects the display persistence to the normal frame rate.  
**STO** Selects the display persistence to infinite.  
**FRZ** Freezes the display.
- 3 **INT**
**INT** Selects internal sync reference from the input video.  
**EXT** Selects the EXT-REF bnc as the sync reference.  
**HFT** Hands Free Timing™ automatically switches the display between internal and external syncs, so easily showing timing errors.
- 4 **CDM** Selects custom graticule and gain.

Fig 4

# OPERATING INSTRUCTIONS

## AUDIO MENU

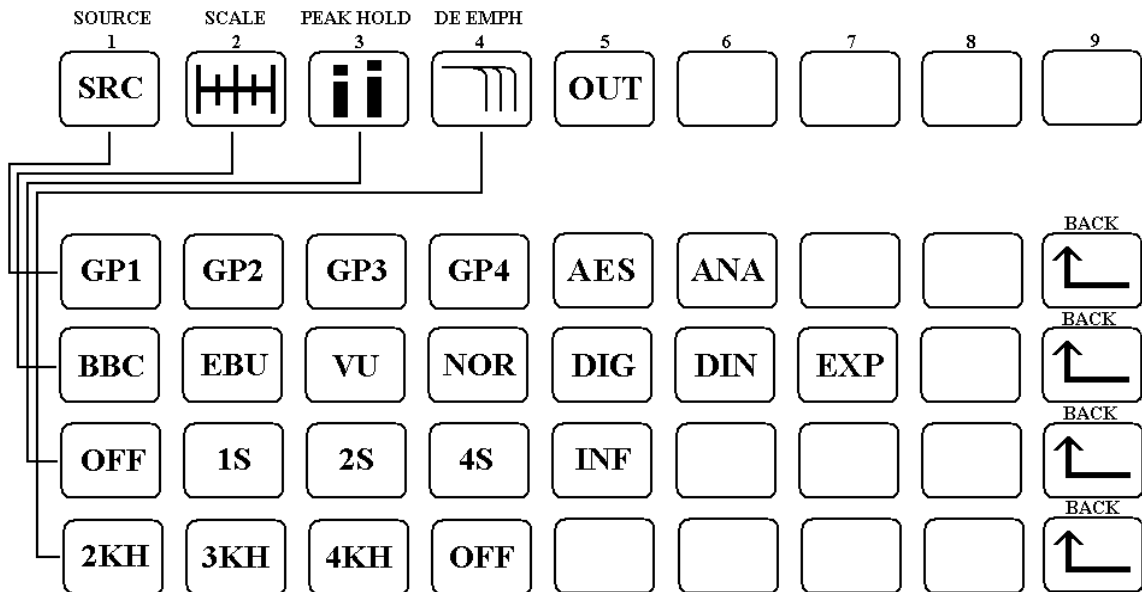

- |   |  |   |                       |
|---|--|---|-----------------------|
| 1 |  | <ul style="list-style-type: none"> <li> Selects embedded audio Group 1.</li> <li> Selects embedded audio Group 2.</li> <li> Selects embedded audio Group 3.</li> <li> Selects embedded audio Group 4.</li> <li> Selects AES audio input.</li> <li> Selects analogue audio (option).</li> <li> Up one level in the menu.</li> </ul>                    |                       |
| 2 |  | <ul style="list-style-type: none"> <li> Selects BBC Type II audio scale.</li> <li> Selects EBU audio scale.</li> <li> Selects VU audio scale.</li> <li> Selects NORDIC audio scale.</li> <li> Selects DIGITAL audio scale.</li> <li> Selects DIN audio scale.</li> <li> Selects expanded DIN scale.</li> <li> Up one level in the menu.</li> </ul>    | } See following page. |
| 3 |  | <ul style="list-style-type: none"> <li> Selects audio bars peak hold to off.</li> <li> Selects 1 second audio bars peak hold time.</li> <li> Selects 2 seconds audio bars peak hold time.</li> <li> Selects 4 seconds audio bars peak hold time.</li> <li> Selects infinite audio bars peak hold time.</li> <li> Up one level in the menu.</li> </ul> |                       |
| 4 |  | <ul style="list-style-type: none"> <li> Selects 2KHz de emphasis.</li> <li> Selects 3KHz de emphasis.</li> <li> Selects 4 KHz de emphasis.</li> <li> Selects de emphasis to off.</li> <li> Up one level in the menu.</li> </ul>   |                       |
| 5 |  | <p>Selects the audio output and phase display source. The selection is displayed in the top status bar:</p> <p>CH:1&amp;2 CH:3&amp;4 CH:1 MONO CH:2 MONO CH:3 MONO CH:4 MONO</p>  |                       |

Fig 5

# OPERATING INSTRUCTIONS

## AUDIO SCALES

### AUDIO SCALES

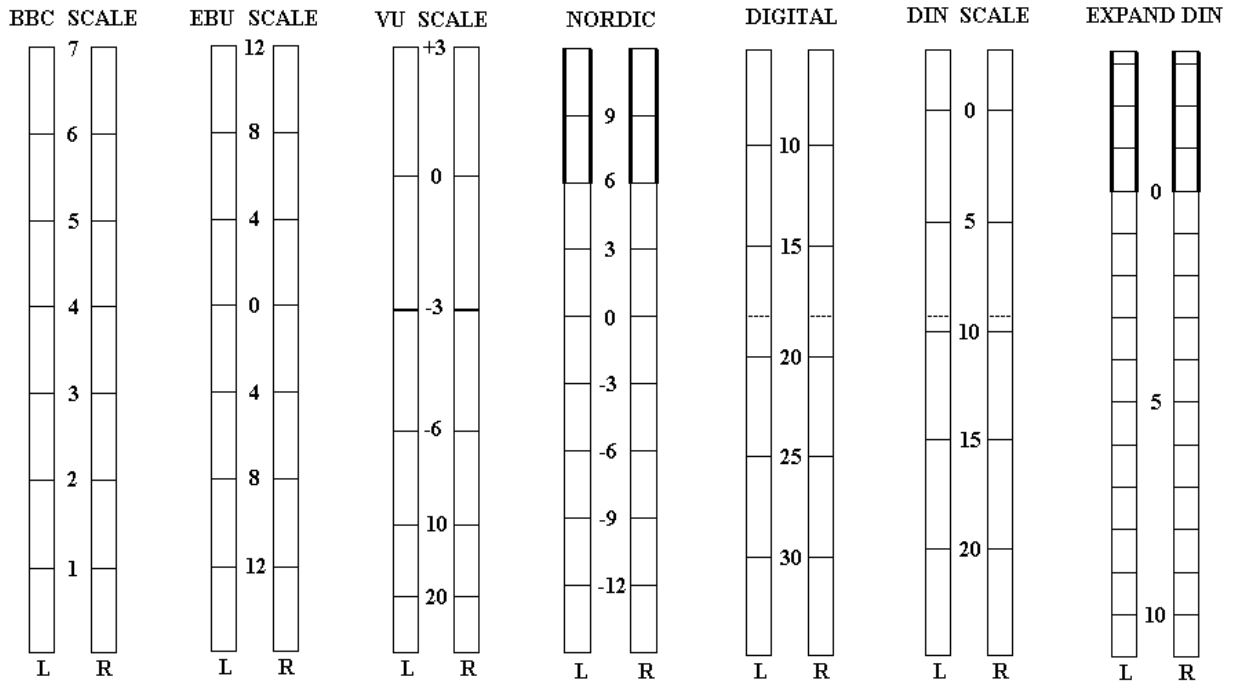
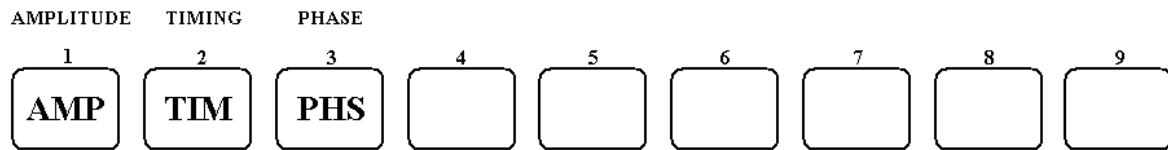

Fig 6

## OPERATING INSTRUCTIONS

### CURSOR MENU



- AMP** The amplitude corresponding to each cursor in mV, is displayed in the status area, along with the difference between the two values.
- TIM** The time corresponding to each cursor is displayed in the status area, along with the difference between the two values.
- PHS** The intersection of the cursors represents a phase amplitude measured from the centre and a phase angle value. The phase angle is taken as 0 degrees at the 9 o'clock position. The phase magnitude and angle at the intersection is displayed in the status area.

The cursor positions are moved using the front panel CURS A and CURS B controls. The third control moves both cursors together.

Fig 7

## OPERATING INSTRUCTIONS

### LOGGER MENU

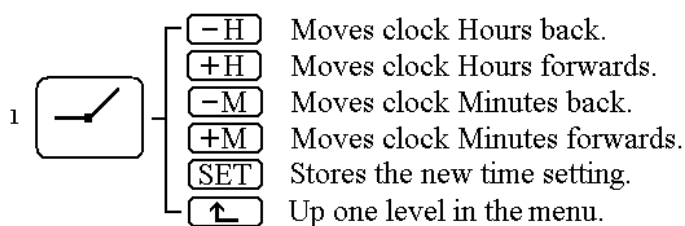
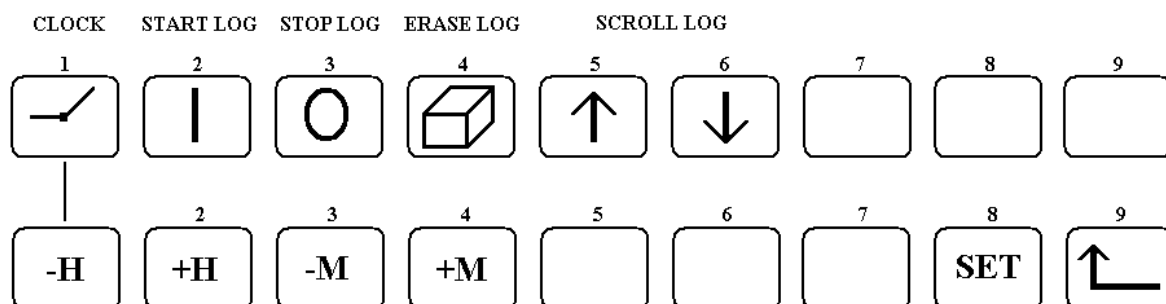

2  Starts the logger. Stores the time of occurrence, the video standard and type of all errors that have been enabled in the top level Alarms menu. All logged errors have a number starting at 1 and going up to a maximum of 980.

3  Stops the logger.

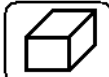
4  Erases all logged errors.

5  Scrolls up the list of logged errors displayed on the top status bar. Says "End of Log" when at the top of the list.

6  Scrolls down the list of logged errors displayed on the top status bar.

The log can be downloaded to a computer via the USB port. See the Remote Control section for more details.

Fig 8

## OPERATING INSTRUCTION

### ALARM MENU

These alarms can be set individually. When set and an error of that type occurs, they will have the following effects:

If the logger is running the error will be logged

If the logger is not running the error count will be displayed in the top status bar in Data mode and an audible warning will sound.

### With SD Video Input

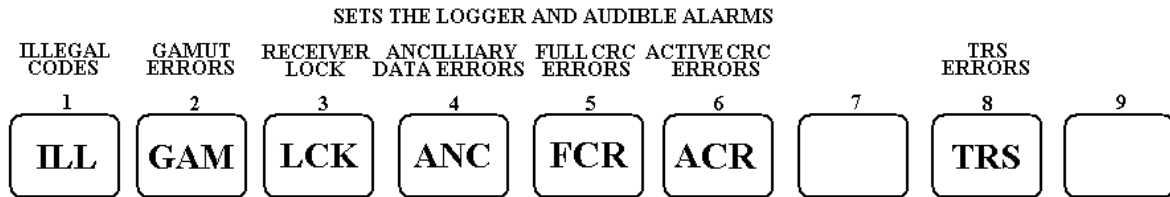

- ILL** Detects illegal values in the incoming video data stream.
- GAM** Detects out of gamut values in the incoming video data stream (+3%, -1%)
- LCK** Indicates the unit is not locked to the incoming video.
- ANC** Detects illegal values in the ancillary data packets in the the video data stream.
- FCR** Detects errors in the Full Field CRC of the incoming video data stream.
- ACR** Detects errors in the Active Picture Area CRC of the incoming video data stream.
- TRS** Detects errors in the EAV and SAV values in the incomming video data stream.

Fig 9a

### With HD Video Input

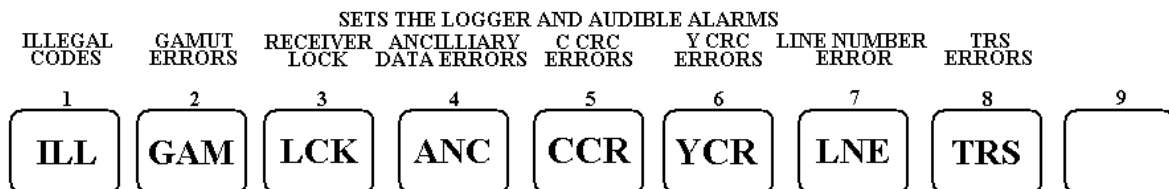

- ILL** Detects illegal values in the incoming video data stream.
- GAM** Detects out of gamut values in the incoming video data stream (+3%, -1%)
- LCK** Indicates the unit is not locked to the incoming video.
- ANC** Detects illegal values in the ancillary data packets in the the video data stream.
- CCR** Detects errors in the Chroma CRC of the incoming video data stream.
- YCR** Detects errors in the Luma CRC of the incoming video data stream.
- LNE** Detects line numbering errors in the incoming video data stream.
- TRS** Detects errors in the EAV and SAV values in the incomming video data stream.

Fig 9b

## OPERATING INSTRUCTIONS

### DATA MENU

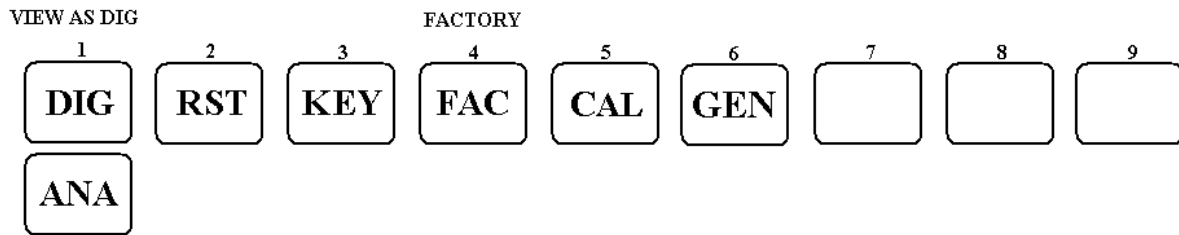



- 1 **DIG**  This is the totally digital display mode.  
 This allows an analog representation of the digital input, complete with analog syncs.
- 2 **RST** Resets all the error counters.
- 3 **KEY** Causes an audible "beep" when any key is pressed.
- 4 **FAC** Resets the unit to a standard default "Factory Setting".
- 5 **CAL** Calibrates the cable level display. Using a cable clone, switch in attenuation and click on the matching icon:  
0DB -5 -10 -15 -20 -25  
Then click on the SET icon to store the settings.
- 6 **GEN** Controls the Option 3 test pattern generator.  
See the section at the back of this manual.

Fig 10

## OPERATING INSTRUCTIONS

### DISPLAY MENU



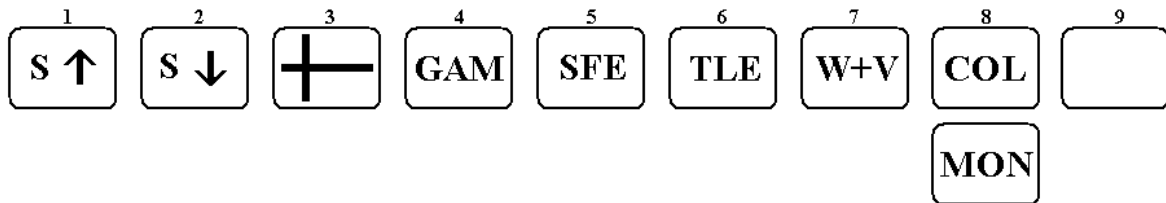





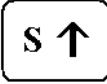
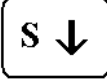
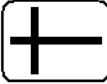

- 1  Increases the scale brightness.
- 2  Decreases the scale brightness.
- 3  Picture H/V delay to show blanking areas.
- 4  This mode shows R,G and B traces superimposed, with a 1H timebase, and low pass filtering. There are gamut limit lines at +3% and -1%.
- 5  Selects the safe area display to:  
OFF 16:9 14:9 4:3  
 When selected, the unit switches to picture mode.
- 6  Selects TILE mode, which shows waveform, vector, audio and picture in four display quadrants. The individual main menu keys control each quadrant. Line Select and Gains don't operate in this mode.
- 7  Allows a TILE display, but with the audio and picture areas blanked.
- 8   Allows the waveform parade display to be in colour.  
 Allows the waveform parade display to be in monochrome.

Fig 11

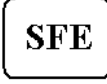
### PICTURE MODE

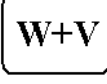
Pressing the PICTURE key gives a full screen picture. Repeated pressing toggles between 16:9 and 4:3 aspect ratios. Press any other main menu key to exit.

## REMOTE CONTROL

To control the unit via a USB interface.

### Installation of Software

Install the software supplied on the CD-ROM on to a PC. The program should auto-start. If not, click on the program:

**setup.exe**

When it is installed connect the MS9000 to the PC's USB port by the supplied USB A to USB A cable.

Switch on the MS9000.

The first time, the PC will ask for the location of the drivers.

Using the browser display, select the path as Program Files\MS9000 and press OK.

This will load the drivers. Remove the CD-ROM and store safely.

Start the MS9000 utility program from the PC Start menu...MS9000

Or by double clicking on the program icon located in the folder:

**Program Files/MS9000/MS9000\_rem.exe**

### Operation of Software

**Get a Log** This button downloads the error logs from the MS9000.

**Print Log** this button will send the log to your printer.

**Erase log** will clear the logger memory in the MS9000.

Note that the logger memory is automatically cleared when the logger is started.

**1 Frame** button will download the current display of the MS9000.

**Continuous** will download the display from the MS9000 constantly until

The **Stop** button is pressed.

**Files** button opens a window for saving and recalling downloaded displays.

To store a downloaded display enter a file name for the display in the box provided

Then press the **Store** button.

To recall a stored display use the Select Folder and Select File boxes to find a display file then press the **Display** button.

Pressing the **Cancel** button returns to the normal window.

**Clear** button clears both the log and display areas.

**Exit** closes the utility.

## ADDITIONAL FUNCTIONS

### **To start the unit in a known state**

Powering on the unit normally will recall the settings previously used, but if previous settings were non-standard, factory set mode can be established to allow faster use.

Press the data key, then the Factory settings Icon [FAC].

Factory mode can also be loaded at boot up. With the unit turned off, hold down the front panel REC key and switch on. Continue holding the key down for at least 5 seconds.

### **To store and recall user settings**

8 sets of front panel setting can be stored for later recall.

To Store Settings: Press the front panel STR button, then a menu 1 - 8 key.

To Recall the settings: Press the front panel RCL button, then a menu 1 - 8 key.

### **Power Source**

The Hamlet MS9000 can be powered from the supplied adaptor, providing 12V @ 2 amps regulated, or from the optional external battery pack.

## TECHNICAL SPECIFICATION

### INPUTS WITH SDI-CST MODULE

- INPUT** BNC connector. Input impedance 75 ohms. Max d.c. +/- 10V.  
SMPTE 259M serial digital at 800mV p/p.  
Auto equalised up to 350 metres of cable at 270mb/s.  
PAL or NTSC composite video 0.5 to 2.0V p/p.
- SDI output.** BNC connector. Output impedance 75 ohms. Equalised version of the serial digital input.
- Ext-ref / AES input.** BNC connector. Input impedance 75 ohms. Max dc +/- 3 volts.  
Video 0.5 to 2.0V p/p.  
Digital Audio min 150mV p/p, max 3V p/p conforming to S/PDIF, AES3, IEC60958 or EIAJ CP1201.

### INPUTS WITH HD-SD MODULE

- SD/HD digital input.** BNC connector. Input impedance 75 ohms. Max d.c. +/- 10V.  
SMPTE 259M serial digital at 800mV p/p.  
SMPTE 292M high definition serial digital at 800mV p/p.  
Auto equalised up to 350 metres of cable at 270mb/s.  
Auto equalised up to 140 metres of cable at 1.485Gb/s.
- SD/HD digital output.** BNC connector. Output impedance 75 ohms. Equalised version of the serial digital input.
- Ext-ref / AES input.** BNC connector. Input impedance 75 ohms. Max dc +/- 3 volts.  
Video 0.5 to 2.0V p/p.  
Digital Audio min 150mV p/p, max 3V p/p conforming to S/PDIF, AES3, IEC60958 or EIAJ CP1201.

### OUTPUT OPTION

- XVGA** DVI-I socket with analogue and digital signals.

### AUDIO MONITORING OUTPUT

- 3.5mm stereo jack socket.

### REMOTE CONTROL

- USB

## TECHNICAL SPECIFICATION

### POWER

10 to 13V d.c. to 4 pin XLR socket. 2A max.

### ENVIRONMENT

Indoor use, 5 to 45 deg.C. ambient to 2,000m.

Max humidity 80% to 31 deg.C decreasing to 50% at 40 deg.C.

Overtoltage category 2. Pollution degree 1.

Weight 3Kg.

### DISPLAY AREAS

Display 129.0mm x 96.8mm viewing area.

Resolution 1024 pixels wide x 768 pixels high.

### WAVEFORM MONITOR

Response Flat is +/- 1% 50Hz to 5.5MHz (30.0MHz in HD modes).  
Low Pass is -3db @ 1.5MHz, -60db @ 6.75MHz.

Timebase H, 2H and Hmag (x5).  
V, 2V and Vmag.  
Line select is any line from the frame.  
Parade is YCrCb left to right.

### VECTOR MONITOR

Video Traditional component display.  
Accuracy 0.2%. B/width 3.4MHz (15MHz in HD modes).

Audio Stereo phase display of CH1 or CH2 audio pair.  
Phase accuracy 2 deg.

### AUDIO MONITOR

Accuracy Better than 0.1db over full scale range.

Characteristics BBC, EBU, VU, NORDIC, DIGITAL, DIN and  
EXPANDED DIN.

## TROUBLE SHOOTING

### **Unit appears dead:**

Check that the 12V supply adaptor is plugged into the unit and that this is plugged into an operational mains supply, or the external battery pack is fresh. Ensure the front panel power switch is illuminated.

### **No video displayed:**

If there is no video signal connected to the selected input, the screen will display the message “No Signal”.

### **Unusual display:**

The unit may be set to a non-standard mode. Reset the unit as follows.  
Press the DATA key, then the Factory settings Icon [FCT].

### **Displays not locked:**

May be in external reference mode. Press the menu EXT REF key to cancel. This may need pressing twice to step through the HFT mode.

## SERIAL DIGITAL BASICS

625 and 525 digital component video is produced by applying a 4:2:2 sampling structure to the analog signal. This process is defined by a sub-set of international standards ITU-R BT.601 and BT.656. (these were formerly known as CCIR-601 and CCIR-656. The label 'CCIR601' is commonly applied to digital video coded in this manner.)

The luminance (Y) component is sampled at 13.5 MHz, and the colour difference components (U and V) are both sampled at 6.75 MHz. With 10 bit quantisation, this results in a data stream of 10 bit words at a clock frequency of 27 MHz. If the signal source uses 8 bit quantisation, 10 bit data is used with the two least significant bits of each sample code set to binary zero. This is to maintain the same data rate.

The quantizing levels employed in the analog to digital conversion are set to give 66.4mV headroom above peak white and 51.1mV below black. Coded U and V signals have 50mV above and below their normal maximum and minimum excursions.

The synchronisation pulses are discarded in the coding process, and are replaced by Timing Reference Signals (TRS) which are inserted into the data stream to serve the same purpose. Two TRS's are used to synchronise the data stream, EAV (End of Active Video) and SAV (Start of Active Video). These are placed at the beginning and end of the horizontal video blanking period. see fig 15.

Each TRS consists of 4 words:

- 1) 3ff hex ie all '1's
- 2) 000 hex ie all '0's
- 3) 000 hex ie all '0's
- 4) XYZ, which determines the type of TRS pulse:

XYZ:

Bit 9: always '1'

Bit 8: 0 = frame 1    1 = frame 2

Bit 7: 0 = normal    1 = field blanking

Bit 6: 0 = SAV    1 = EAV

Bit 5: Bits used for Hamming correction.

Bit 4: Bits used for Hamming correction.

Bit 3: Bits used for Hamming correction.

Bit 2: Bits used for Hamming correction.

Bit 1: Always '0'

Bit 0: Always '0'

## SERIAL DIGITAL BASICS

The period between EAV and SAV is not used by normal video and is available for other purposes eg: error checking, timecodes or embedded audio.

Illegal Values: The values 0 and 3FF hex are used solely by TRS pulses (EAV and SAV) they must not appear anywhere in the active video area.

Out of Gamut: Values apart from the illegal values which should not be used.

Luminance is defined as being between peak white, 700mV 3AC, hex and black, 0mV 040 hex.

Chroma is defined as being between max positive, 350mV 3C0, hex and max negative, -350mV 040 hex.

The values above and below these are termed out of gamut.

The data is serialised using an NRZ (None Return to Zero) code to produce a 270 Mb/s signal. This coding method removes any low frequency component and is insensitive to polarity. The data has to be scrambled first to avoid the possible transmission of all '0's. This data is output at 800mV p-p to normal 75 ohm video coaxial cable.

Due to the high frequencies, the cable losses are quite high, typically 10dB per 100 metres at 270 MHz. To allow acceptable cable lengths, automatic cable equalisers are used at the receiver which usually allow up to 300 metres of cable to be used. It is important that standard cable is used, otherwise the equaliser will not compensate correctly.

Suitable cable is:      PSF 2/3          BELDEN 8281          F&G 1.0/6.6

### DIGITAL ERROR DETECTION OVERVIEW

In order to check if the digital video signal has been received correctly a Cyclic Redundancy Check (CRC) can be made on each frame in the generating equipment, this four digit number is then placed in a 'packet' and put in the EAV-SAV space of one line of each field.

At the receiving equipment the incoming video field also has a Cyclic Redundancy Check number calculated, this value is then compared with the 4 digit number sent in the packet. If the two numbers are not identical an error has occurred between transmission and reception of the signal.

## SERIAL DIGITAL BASICS

This type of error detection is known as Error Detection and Handling or EDH and is defined by SMPTE RP165. In practice two check sums are sent per frame, one for the active video period and one for the full frame. A typical packet consists of:

The Header: (000, 3FF, 3FF) This always precedes an EDH packet.

Data ID: (1F4)

Block Number: (200)

Data Count: This contains the number of words that follow.

Active picture crc: 3 words

Full-field crc: 3 words

Error flags: 3 words

Reserved: 7 words

Check Sum: This is used to test for transmission errors.

## EMBEDDED AUDIO OVERVIEW

The period between the EAV and SAV markers can be used to send embedded digital audio signals. This is known as SMPTE 272M. Up to 16 separate audio signals may be sent in a single video channel. These are organised as four GROUPS of four signals, the four signals are often two stereo pairs. Typically only one group will be used, giving two stereo pairs of audio. The audio data is digitised in the sending equipment to 20 bits of resolution, usually at a 48 KHz sample rate. Often only 16 bits are used in practice. The digitised data is arranged in packets which are placed in the EAV-SAV space.

A typical packet consists of:

The Header: (000, 3FF, 3FF) This always precedes an audio packet.

Data ID: This contains the Audio Group number.

Block Number: AES blocks have 192 'frames' of audio data

Data Count: This contains the number of words that follow.

Audio Sample:

Audio Sample:

Audio Sample:

Audio Sample:

Check Sum: This is used to test for transmission errors.

Each audio sample consists of a sample of all four audio signals,  
eg: Channel 1 left, Channel 1 right, Channel 2 left, Channel 2 right.

Each signal requires 3 words to hold all 20 bits data, thus each audio sample has 12 words in it. Typically 3 or 4 audio samples are sent in each EAV-SAV period.

As with the video signal, words which consist of all '1's or all '0's are not allowed.

## SERIAL DIGITAL BASICS

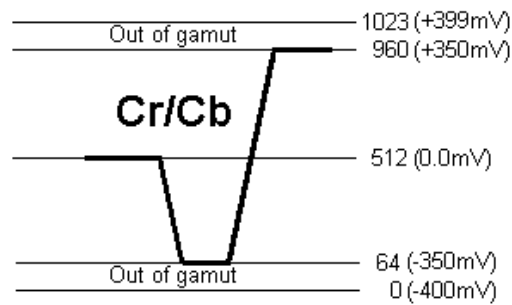
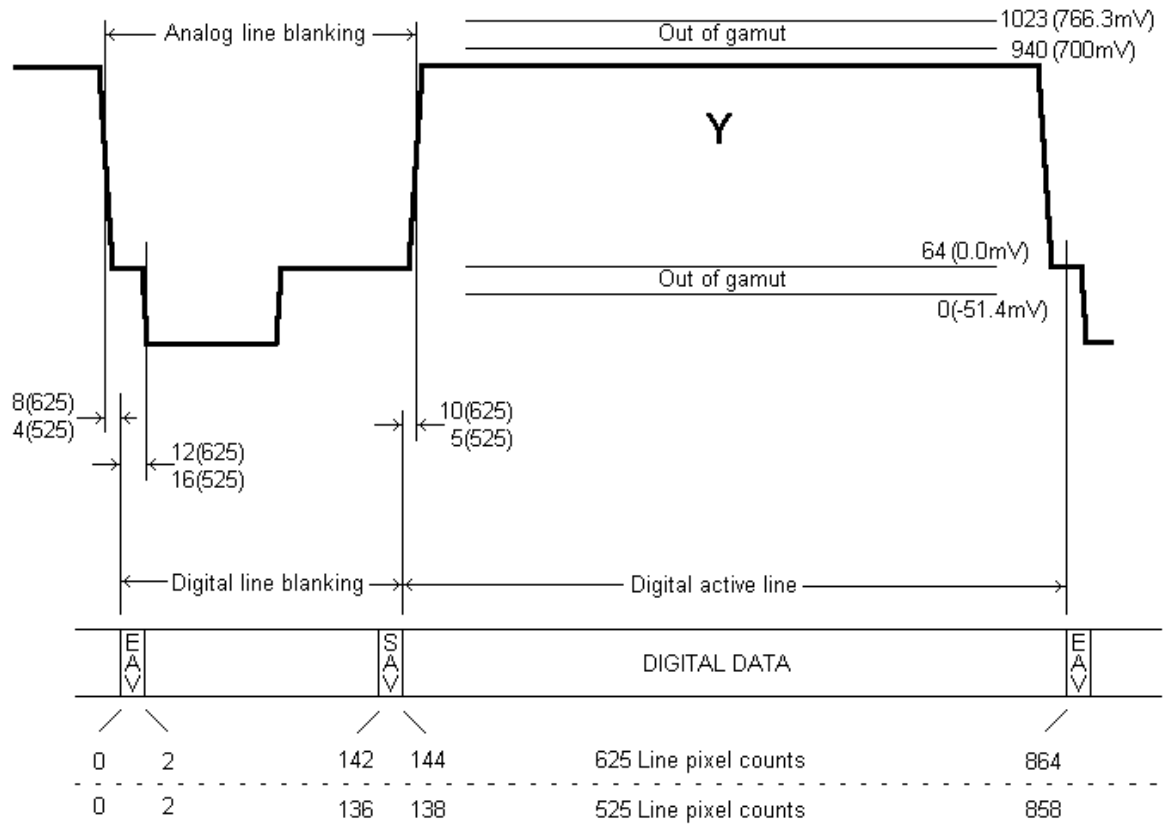
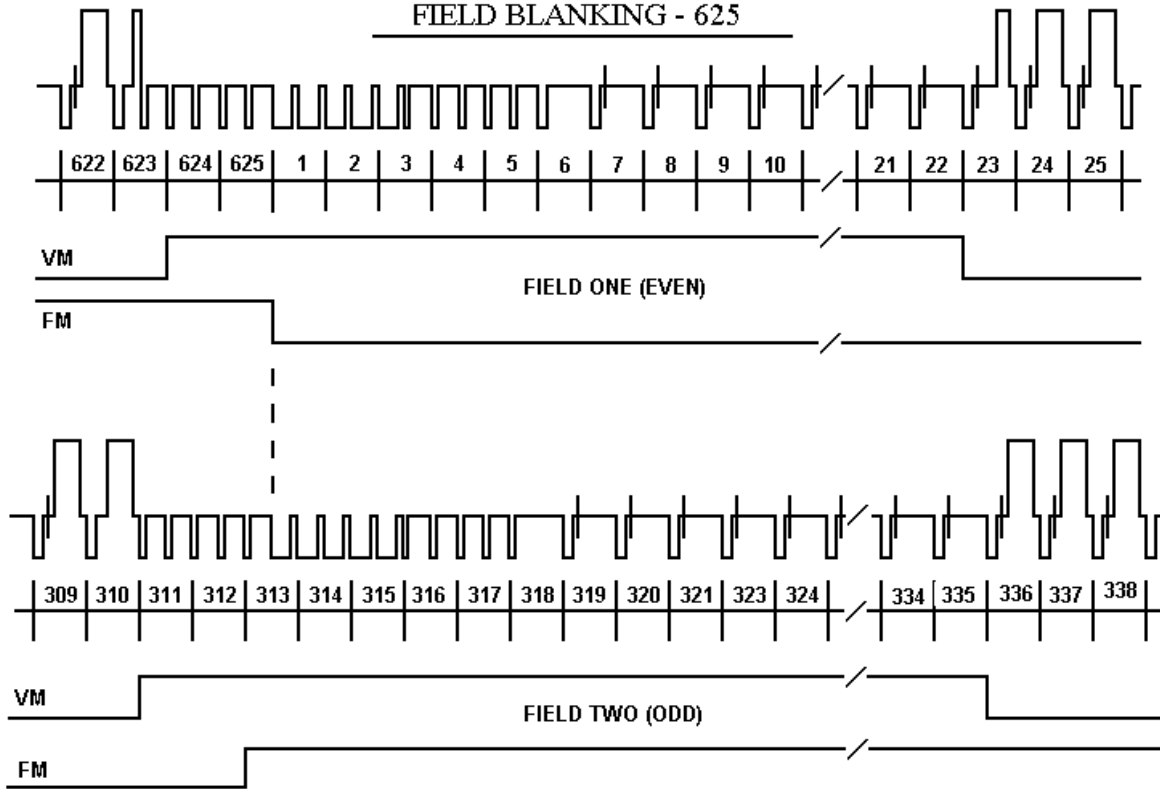

Fig 12

### SERIAL DIGITAL BASICS

#### FIELD BLANKING - 625



#### FIELD BLANKING - 525

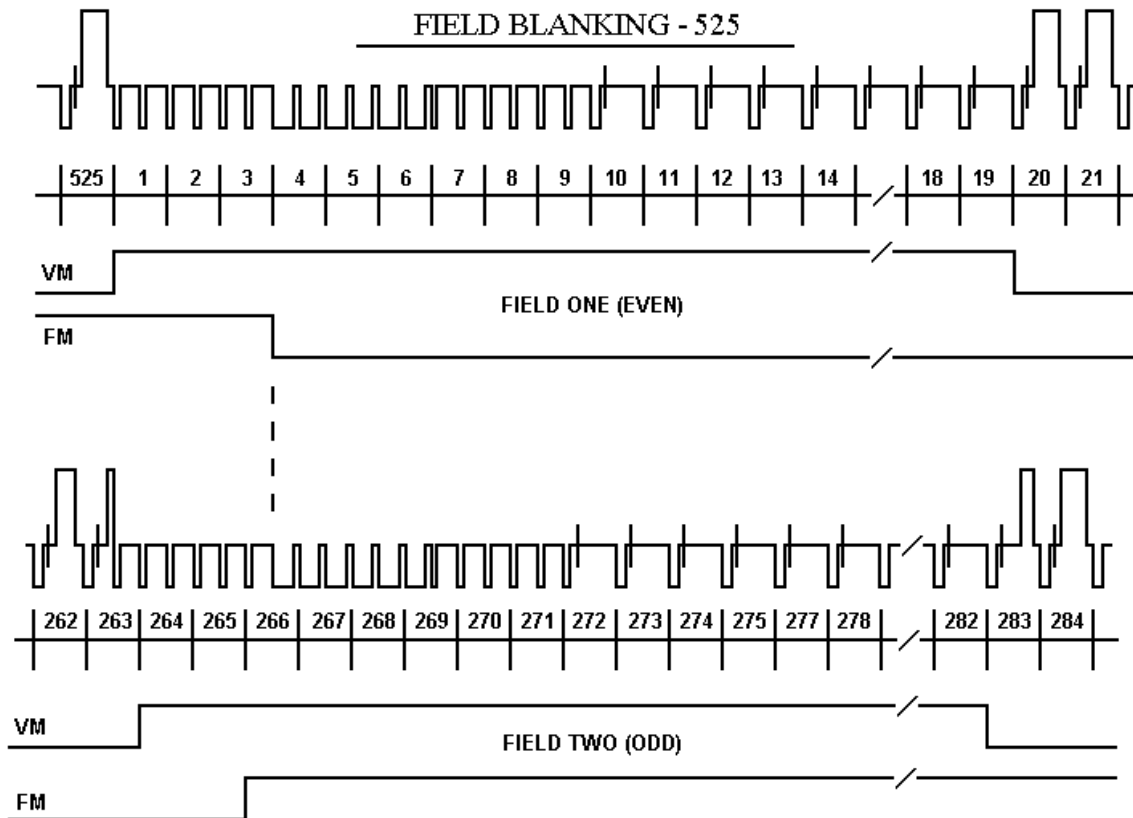

Fig 13/14

## HD SERIAL DIGITAL BASICS

### BIT SERIAL DIGITAL INTERFACE DEFINED BY SMPTE 292M.

HDTV digital component video is produced by applying a 4:2:2 sampling structure to the analog signal. The luminance component (Y) is sampled at 74.25 MHz, the colour difference components U & V) are both sampled at 37.125 MHz.

The Y stream is quantised to 10 bits resolution and Timing Reference Signals (TRS) are added at the beginning and end of the horizontal video blanking period.

The U & V streams are also quantised to 10 bits and then interleaved to give a C stream at 74.25 MHz. TRS are added at the beginning and end of the horizontal video blanking period.

The 74.25MHz Y and C streams are then interleaved to produce a single stream at 148.5MHz.

This data is then scrambled and serialised using a None Return to Zero (NRZ) code to produce a 1.485 GHz signal.

The TRS at the end of the horizontal blanking period is called Start of Active Video (SAV) it consists of 4 words:

- 1) 3FF hex ie all '1's
- 2) 000 hex ie all '0's
- 3) 000 hex ie all '0's
- 4) XYZ, which determines the type of TRS pulse, consisting of:

Bit 9: Always '1'

Bit 8: 0=frame 1, 1=frame 2

Bit 7: 0=normal 1=field blanking

Bit 6: 0=SAV 1=EAV

Bit 5: Bits used for Hamming correction.

Bit 4: Bits used for Hamming correction.

Bit 3: Bits used for Hamming correction.

Bit 2: Bits used for Hamming correction.

Bit 1: Always 0

Bit 0: Always 0

The TRS at the beginning of the horizontal blanking period is called End of Active Video (EAV) it consists of 8 words: The first 4 are the same as for SAV, followed by 2 words containing the current line number and 2 words containing a Cyclic Redundancy Check (CRC) for all the preceding words in the line. The period between EAV and SAV is not used by normal video and may be used for embedded audio or timecode data.

### ILLEGAL VALUES

The values 000 and 3FF hex are used solely by TRS pulses (EAV & SAV) they must not appear anywhere in the active video area.

## SAMPLE STRUCTURE

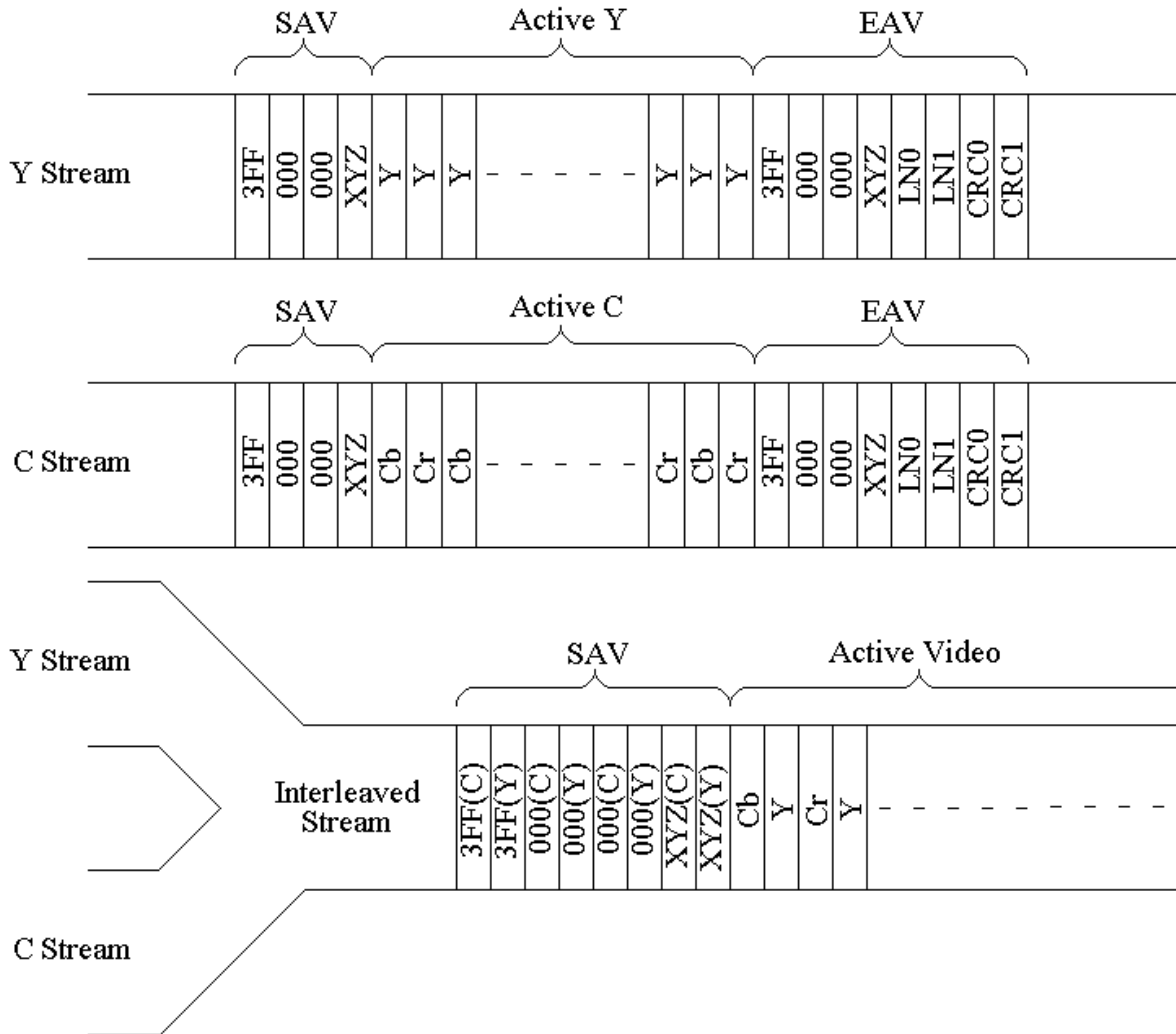

Fig 15

## PARALLEL DIGITAL INTERFACES

Several parallel video Standards can be used with the above serial interface. These are defined in SMPTE 274M for 1920 x 1080 scanning and SMPTE 296M for 1280 x 720 scanning.

### **SMPTE 274M**

Several sub-standards for this are defined:

#### 1920 x 1080/60/2:1

1920 samples/active line 1080 active line/frame 30PsF segmented format.  
74.25 MHz Sample frequency 2200 total samples/line 1125 total lines/frame

#### 1920 x 1080/59.94/2:1

1920 samples/active line 1080 active line/frame 29.97PsF segmented format.  
74.176 MHz Sample frequency 2200 total samples/line 1125 total lines/frame  
This standard gives an exact frame rate compatibility with NTSC.

#### 1920 x 1080/50/2:1

1920 samples/active line 1080 active line/frame 25PsF segmented format.  
74.25 MHz Sample frequency 2640 total samples/line 1125 total lines/frame

#### 1920 x 1080/30/1:1

1920 samples/active line 1080 active line/frame 30 Hz Progressive scan.  
74.25 MHz Sample frequency 2200 total samples/line 1125 total lines/frame

#### 1920 x 1080/29.97/1:1

1920 samples/active line 1080 active line/frame 29.97 Hz Progressive scan.  
74.176 MHz Sample frequency 2200 total samples/line 1125 total lines/frame  
This standard gives an exact frame rate compatibility with NTSC.

#### 1920 x 1080/25/1:1

1920 samples/active line 1080 active line/frame 25 Hz Progressive scan.  
74.25 MHz Sample frequency 2640 total samples/line 1125 total lines/frame

#### 1920 x 1080/24/1:1

1920 samples/active line 1080 active line/frame 24 Hz Progressive scan.  
74.25 MHz Sample frequency 2750 total samples/line 1125 total lines/frame

#### 1920 x 1080/24sf

1920 samples/active line 1080 activelines/frame 24 Hz segmented frame  
74.25 MHz sample frequency 2750 total samples/line 1125 total lines/frame

#### 1920 x 1080/23.98/1:1

1920 samples/active line 1080 active line/frame 23.98 Hz Progressive scan.  
74.176 MHz Sample frequency 2750 total samples/line 1125 total lines/frame

## HD SERIAL DIGITAL BASICS

### SMPTE 296M

Several substandards for this are defined:

#### 1280 x 720/60/1:1

1280 samples/active line 720 active line/frame 60 Hz Progressive scan.  
74.25 MHz Sample frequency 1650 total samples/line 750 total lines/frame

#### 1280 x 720/59.94/1:1

1280 samples/active line 720 active line/frame 59.94 Hz Progressive scan.  
74.176 MHz Sample frequency 1650 total samples/line 750 total lines/frame

#### 1280 x 720/50/1:1

1280 samples/active line 720 active line/frame 50 Hz Progressive scan.  
74.25 MHz Sample frequency 1980 total samples/line 750 total lines/frame

### EMBEDDED AUDIO

The period between EAV and SAV can be used to send embedded digital audio signals. This is defined in SMPTE 299M. Up to 16 separate audio signals may be sent in a single video channel. These are organised as four GROUPS of four signals, the four signals are often two stereo pairs. Typically only one group will be used, giving two stereo pairs of audio. The audio data is quantised in the sending equipment to 24 bits of resolution, usually at 48 KHz sample rate in AES/EBU format. The digitised data is arranged in packets which are placed in the EAV-SAV space.

**A packet consists of:**

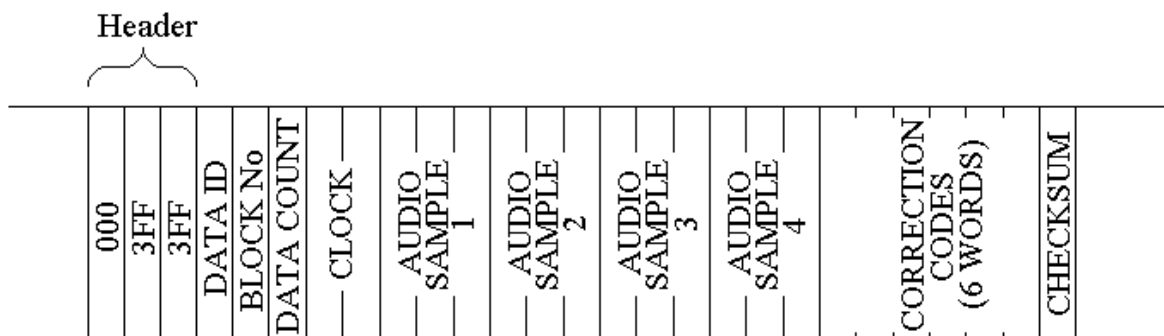

Fig 16

## HD SERIAL DIGITAL BASICS

The Header: (000, 3FF, 3FF)

Data ID: This contains the Audio group number.

Data block number: AES frames have 192 samples of audio data

Data Count: This contains the number of words that follow, always 218 hex

Clock: 2 words containing the number of video clocks that have elapsed between the first word of EAV and the time the audio sample was made, it is used by the receiving equipment to reconstruct the audio signal with the correct phase delay.

Audio Sample 1: Consists of four words

Audio Sample 2: Consists of four words

Audio Sample 3: Consists of four words

Audio Sample 4: Consists of four words

### Error Correction Codes

Consist of six words used by the receiving equipment to detect or correct errors in the 24 words from the header to the last word of audio sample 4 inclusive.

Check Sum This is the sum of all previous words in the packet except the header words.

Each audio packet contains a sample of all four audio signals

eg: Channel 1 left, Channel 1 right, Channel 2 left and Channel 2 right.

Each audio signal requires 3 words to hold all 24 bits, thus each audio packet has 12 words of audio data.

Typically one or two packets are sent in each EAV-SAV period.

These audio data packets are placed in the Chroma data stream only.

### Audio Control Packets.

The audio control packet structure is similar to the audio data packet.

Data in the packet includes the audio sample rate eg 48 KHz,

the number of active channels out of the possible 4,

the delay information between Channel 1 audio and Channel 2

and delay information between Channel 3 audio and Channel 4.

Audio control packets are placed in the Luminance Stream, this is sent once per frame in the second line after the switching point.

As with the video signal, words consisting of all '1's or all '0's are not allowed.

## COMPOSITE BASICS

### COMPONENT COLOUR

The colour picture can be distributed in two forms, whether in 625 or 525 line standards:

#### RGB

This is the basic signal produced by a camera etc and fed to a colour CRT. It consists of three primary signals, **Red**, **Green** and **Blue**. By convention, black level is at 0mV and peak brightness is at + 700mV.

#### YCrCb

As the human eye can see less resolution with colours, the video can be modified to take advantage of this to reduce the amount of information needed. The picture is separated into monochrome and colour components. The monochrome Y signal is formed from:

$Y = (0.3 \times \text{Red}) + (0.59 \times \text{Green}) + (0.11 \times \text{Blue})$  approximately.

This signal has black level at 0mV and maximum white level at + 700mV.

The colour components are two colour difference signals:

$Cr = (R - Y)$  and  $Cb = (B - Y)$

These are weighted to give maximum values of +/- 350mV and are bandwidth restricted to half that of the Y component.

#### PAL

Fig 18 shows an encoded 100% colour bar signal. The two colour components of Cr and Cb are used to amplitude modulate a 4.43361875Mhz carrier signal. The two carriers are arranged to be 90 degrees apart before they are combined with the Y luminance signal, so that they can be decoded separately. The PAL system is designed to minimise hue errors by phase reversing the Cr axis on alternate lines (**Phase Alternate Line**). This reversal is copied by the decoder, so that the hue error will now alternate in phase. By combining the chrominance from two adjacent lines, the error is thus cancelled out.

#### NTSC

Fig 19 shows an encoded SMPTE (75%) colour bar signal. The two colour components of Cr and Cb are used to amplitude modulate a 3.579545Mhz carrier signal, but they are first modified into I and Q signals to reduce the overall maximum chrominance level when combined.

# PAL BASICS

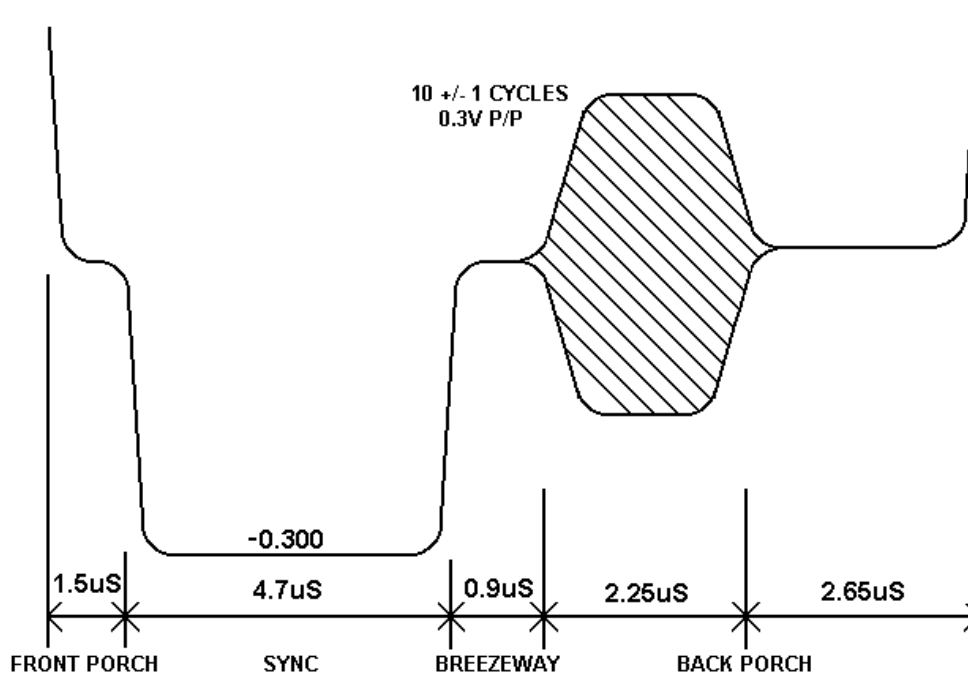
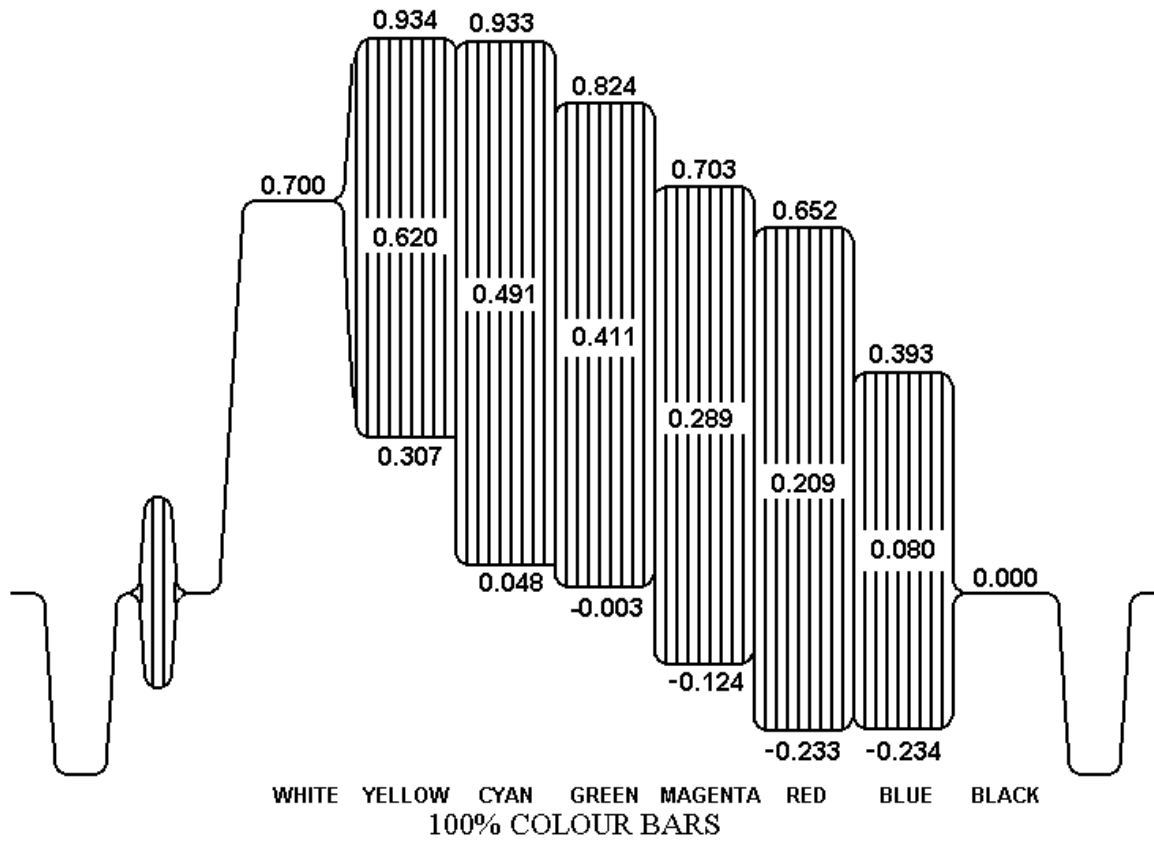

Fig 17

# NTSC BASICS

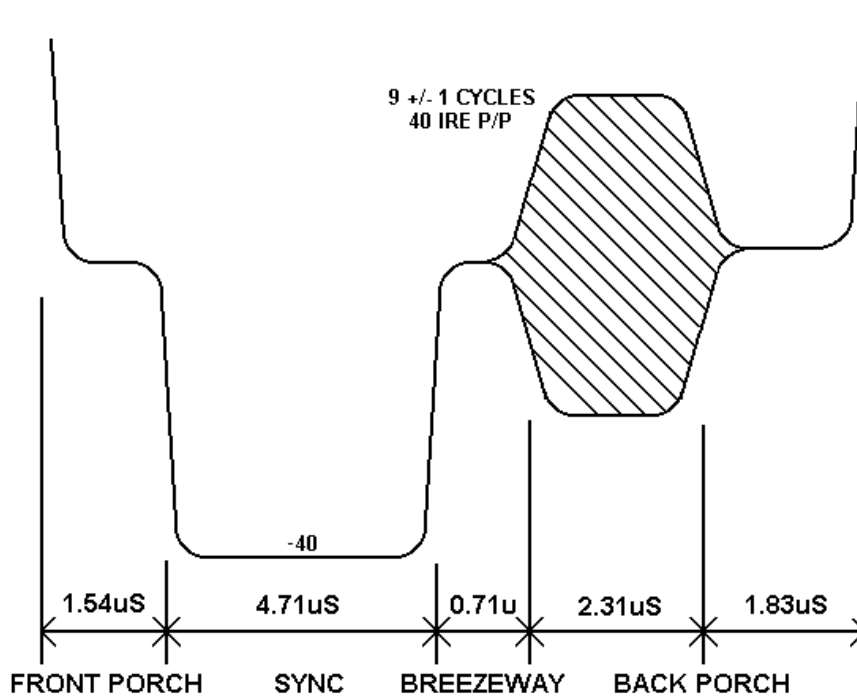
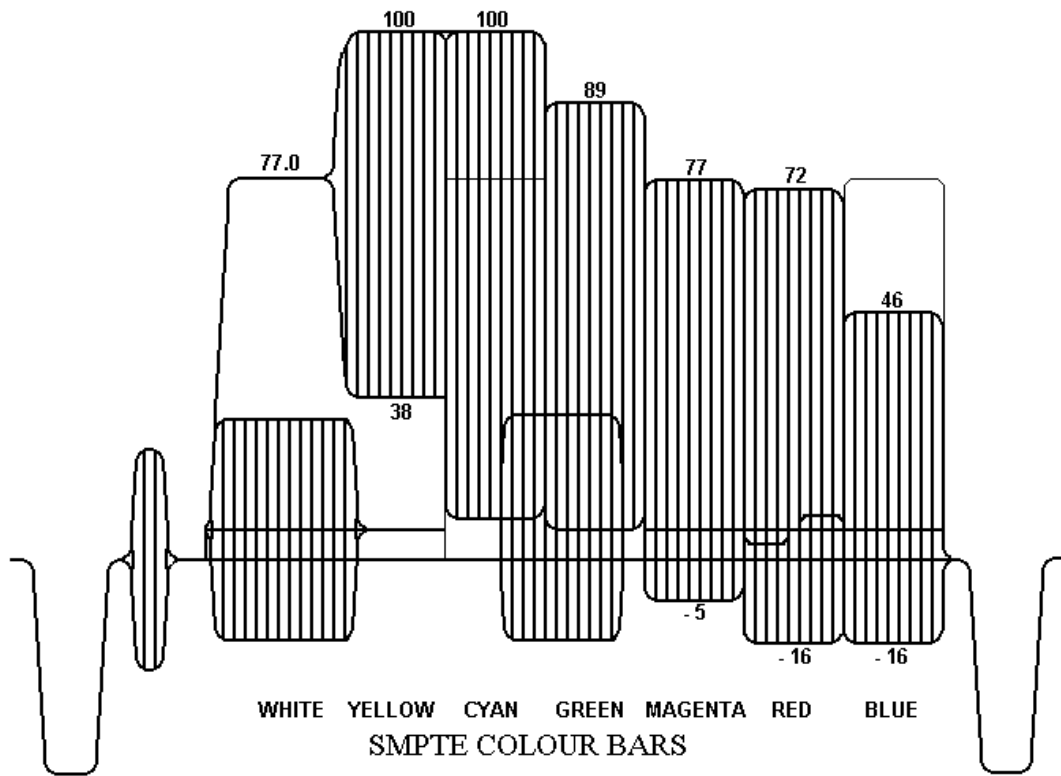

Fig 18

## USEFUL WEBSITES

MS9000	<a href="http://www.monitorscope.tv">www.monitorscope.tv</a>	
HAMLET	<a href="http://www.hamlet.co.uk">www.hamlet.co.uk</a>	
HAMLET (USA)	<a href="http://www.hamlet.us.com">www.hamlet.us.com</a>	
SMPTE	<a href="http://www.smpte.org">www.smpte.org</a>	Society of Motion Picture Television Engineers
DIN	<a href="http://www.din.de">www.din.de</a>	German Standards Institute
EBU	<a href="http://www.ebu.ch">www.ebu.ch</a>	European Broadcasting Union
AES	<a href="http://www.aes.org">www.aes.org</a>	Audio Engineering Society
ITU	<a href="http://www.itu.int">www.itu.int</a>	International Telecommunication Union

## CONTACT DETAILS AND CUSTOMER SUPPORT

For any form of assistance in maintaining your Hamlet MS9000, please contact:

### Corporate Head Office

Hamlet Video International Limited

Maple House 11 Corinium Business Centre Raans Road Amersham Bucks HP6 6FB England

Main Line: +44 (0)1494 729 728

Fax Line: +44 (0)1494 723 237

Free phone (UK) 0500 625 525

E-mail: [service@hamlet.co.uk](mailto:service@hamlet.co.uk) Web site: [www.hamlet.co.uk](http://www.hamlet.co.uk)

### Hamlet USA

Sencore, Inc.

3200 W Sencore Drive, Sioux Falls SD 57107, U.S.A.

Phone: (605) 339-0100

Fax: (605) 339-7032

Toll Free: 1-800-SENCORE (736-2673)

Toll Free: 1-866-4-HAMLET (426-538)

Email: [service@sencore.com](mailto:service@sencore.com) Web site: [www.hamlet.us.com](http://www.hamlet.us.com)

In correspondence concerning this instrument, please quote the serial number, which you will find printed on the label at the back of the unit.

### OPTION 3

This option provides all the features of Option 1 with the addition of a high specification test signal generator for standard and high definition signals. The control menu is accessed by selecting DATA then GEN in the top menu. The output state is described in the top Status line.

STD : 50HZ      PAT : PLUGE      AUD : GP1



- SD** Selects standard definition patterns.
- HD** Selects high definition patterns.
- INT**
  - INT** Selects interlaced standards.
  - PRG** Selects progressive standards.
- 101** Selects 1/1.001 standards.
- STD**
  - Selects INT standards 60Hz, 50Hz, 48Hz.
  - Selects PRG standards 30Hz, 25Hz, 24Hz, 720-60Hz, 720-50Hz.
- PAT**
  - BAR** Selects 100% or 75% Colour Bars.
  - BOW** Selects Bowtie or Split Colour Bars.
  - COL** Selects full screen Red or White.
  - RMP** Selects Ramp or Limit-Ramp patterns.
  - SWP** Selects Sweep or Multiburst patterns.
  - PUL** Selects Pulse & Bar or Pluge patterns.
  - MOD** Selects Mod Steps or SDI check patterns.
  - OPT** For optional patterns, default is SMPTE or Convergence patterns.
  -
- AUD**
  - FRQ** Selects frequency to 125Hz, 250Hz, 500Hz, 1kHz, 2KHz, 4KHz, 8KHz.
  - AMP** Selects amplitudes to 0dB, - 2, - 6, - 8, - 12, - 14, - 18, - 20.
  - GP** Selects audio group (1 of 4).
  - L1** Selects Left channel 1 on/off.
  - R1** Selects Right channel 1 on/off.
  - L2** Selects Left channel 2 on/off.
  - R2** Selects Right channel 2 on/off.
  - 
  -
- AUX**
  - YON** Selects Y data on/off.
  - CON** Selects C data on/off.
  - MPG** Selects Mpeg test moving bar on/off.
  - IDT** Selects Ident Text on/off.
  - EDT** Selects Text Edit mode ——— **CLR**
  - CCL** Selects circle off, 4:3, 16:9. Freq Change VCO/GLK **SET**
  - CAL** Controls the master oscillator **VCO** **SET**
  - BNC** Switches the EXT-REF BNC to AES out, Sync out, AES/Sync input.
  -

## FEATURES

### VIDEO

The video Y and C components can be individually disabled from both outputs.

### EMBEDDED AUDIO

Audio tone, with seven frequencies and eight amplitudes, can be embedded into any of the four groups, with individual channel control.

### AES AUDIO

Audio tone, as above, can be output in AES format to the EXT BNC.

### MPEG TEST

A moving black bar can be added to any pattern to check for stuck frames and MPEG coding errors.

### IDENT TEXT

16 of 64 text characters can be superimposed on the selected pattern. To enter new characters or edit an existing ident caption, go to the GEN - AUX - EDT menu. The cursor can be moved to any 1 of 16 positions using the left/right arrows. The character over the cursor can be selected using the up/down arrows, Selecting from 0-9, A-Z, ( ) ! & @ # . + - thus all character spaces can be set. The CLR key sets all characters to a white space.

### CIRCLE

A white circle can be added to any pattern in 4:3 or 16:9 aspect ratios.

### MASTER OSCILLATOR

The generator clock free running frequency can be calibrated using the menu, in 5ppm steps. Alternatively, it can Genlock to the external reference input.

### EXT-REF BNC

This has four functions, selectable in the AUX menu.

1. AES audio input.
2. Analogue external reference input.
3. AES audio output.
4. Analogue black and syncs output.

All settings are stored when the unit is switched off.

## STANDARDS SUPPORTED

### SMPTE 259

<u>STANDARD</u>	<u>FRAME RATE</u>	<u>CLOCK</u>
711 x 487 (525)	59.94 2:1 I	13.5MHz
702 x 575 (625)	50 2:1 I	13.5MHz

### SMPTE 274M

<u>STANDARD</u>	<u>FRAME RATE</u>	<u>CLOCK</u>
1920 x 1080	60 2:1 I	74.25MHz.
1920 x 1080	59.94 2:1 I	74.25MHz/1001
1920 x 1080	50 2:1 I	74.25MHz
1920 x 1080	30 1:1 P	74.25MHz
1920 x 1080	29.97 1:1 P	74.25MHz/1001
1920 x 1080	25 1:1 P	74.25MHz
1920 x 1080	24 1:1 P	74.25MHz
1920 x 1080	23.98 1:1 P	74.25MHz/1001
1920 x 1080	30 S.F.	74.25MHz
1920 x 1080	29.97 S.F.	74.25MHz/1001
1920 x 1080	25 S.F.	74.25MHz
1920 x 1080	24 S.F.	74.25MHz
1920 x 1080	23.98 S.F.	74.25MHz/1001

### SMPTE 296M

<u>STANDARD</u>	<u>FRAME RATE</u>	<u>CLOCK</u>
1280 x 720	60 1:1 P	74.25MHz
1280 x 720	59.94 1:1 P	74.25MHz/1001
1280 x 720	50 1:1 P	74.25MHz

## PATTERNS

### 100% BARS

100% full colour bars.

Digital levels are Yblack =64, Ywhite = 940, Cr and Cb are 512 +/- 448 max.

### 75% BARS

White as 100% bars. Colours reduced to 75% level.

### SPLIT

Top half of screen is 100% colour bars, bottom half is full red.

### BOWTIE

Y channel is 500KHz. Cr,Cb channels are 502KHz phase adjusted so equal to Y in mid line. Suitable monitoring equipment, e.g. the Hamlet LCDScope 292WVA, produce (Y-Cr) and (Y-Cb) displays to accurately check system gains and timings, with the traditional bowtie displays.

Y Waveform is 438 bits (350mV) p/p centred on 502 bits (350mV).

C Waveform is 448 bits (350mV) p/p centred on 512 bits (350mV).

Timing markers at +/-5nSec and at every 20nSec.

### SWEEP

SD sweeps from 500KHz to 5MHz over the line period, with markers at 1,2,3,4,5 MHz.

HD sweeps from 1MHz to 30MHz over the line period, with markers at 5,10,15,20,25 MHz.

Waveform is 600bits (480mV) p/p centred on 502 bits (350mV).

### PLUGE

Grey scale block for colour monitor gain tracking adjustment and grey/superblack stripes for brightness setting.

Block is 940 bits (700mV), 502 bits (350mV), 239 bits (140mV).

Stripes are at 64 +/- 18bits (+/- 14mV).

### MULTI

525 SD is a white bar at 765 bits (560mV) followed by six frequency bursts at 500KHz, 1.25MHz, 2MHz, 3MHz, 3.58MHz, 4.2MHz at 526 bits (370mV) p/p centred on 502 bits (350mV).

625 SD is a white bar at 765 bits (560mV) followed by six frequency bursts at 500KHz, 1MHz, 2MHz, 3MHz, 4MHz, 5MHz at 526 bits (370mV) p/p centred on 502 bits (350mV).

HD is a white bar at 765 bits (560mV) followed by five frequency bursts at 5MHz, 10MHz, 15MHz, 20MHz and 25MHz at 526 bits (370mV) p/p centred on 502 bits (350mV).

### PULSE+BR

2T luma pulse at 940 bits (700mV), 10T chroma pulse at 502 bits (350mV), bar at 940 bits (700mV).

## **PATTERNS**

### **MOD STPS**

5-step ascending staircase, equal steps of 175 bits (140mV) each.  
Added chroma of Cr at 638 bits and Cb at 652 bits.

### **WHITE**

Plain full white screen.

Y waveform 940 bits (700mV), Cr is 512 bits, Cb is 512 bits.

### **RED**

Plain full red screen.

Y waveform is 250 bits (149mV), Cr is 960 bits, Cb is 409 bits.

### **CONVERGE**

Crosshatch pattern for colour monitor convergence adjustment.

### **DIG CHK**

Top half of the screen is the equaliser test and contains several examples of 19 "0"s followed by 2 "1"s per frame.

Bottom half of the screen is the phase locked loop test and contains several examples of 20 "0"s followed by one "1" per frame.

### **RAMP**

Y waveform is an ascending ramp, running from 64 bits (0mV) to 940 bits (700mV).

Cr and Cb waveforms are ascending ramps, running from 64 (-350mV) to 960 (+350mV)

### **LIM RAMP**

Y waveform is an ascending ramp, running from 1 bit (50 mV below black) to 1022 bits (66 mV above peak white).

## **TECHNICAL SPECIFICATION**

### **OUTPUTS**

SD Serial digital      BNC connector. Output impedance 75 ohms.  
SMPTE 259M, ITU-R BT.601/656 serial component. 800mV pp

HD Serial digital      BNC connector, output impedance 75 ohms.  
SMPTE 292, serial component. 800mV pp

Full 10 bit pattern generation.